

SPARE PARTS

FOR PROGRESSIVE CAVITY PUMPS

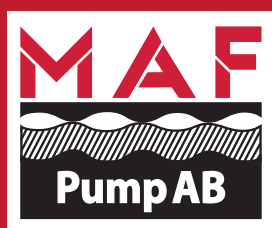
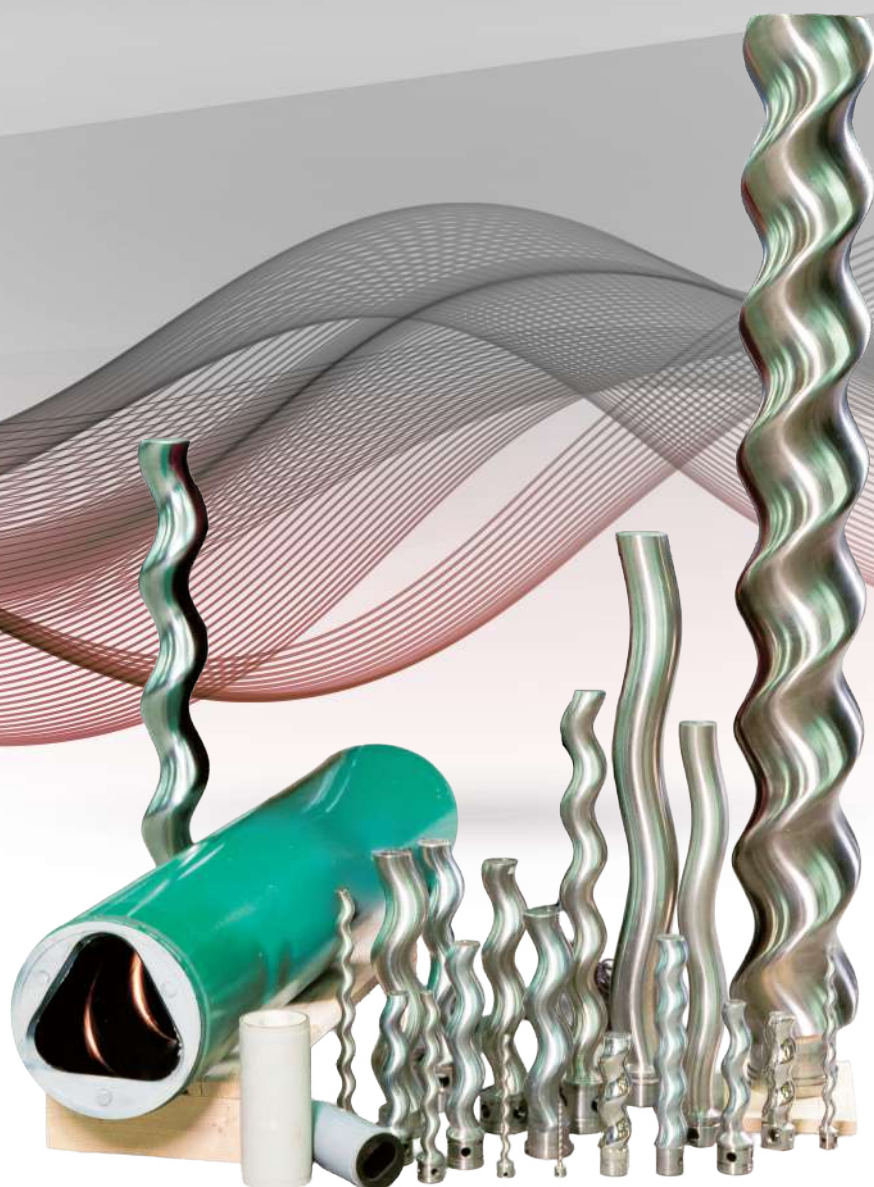

SPARE PARTS CATALOGUE
PROGRESSIVE CAVITY PUMPS

www.mafpump.se

Over 30 years of experience of pumps

We have been in business for more than 30 years, and most of our employees have worked in the industry all their working lives. In other words, we have a great deal of experience, and we are happy to provide advice, service and spare parts - regardless of the make of your pump or sludge dewaterer.

Pumps and service for companies and municipalities

We supply pumps and spare parts to operations such as wastewater treatment plants, the pulp and paper industry, and the food industry – serving both private companies and municipalities.

With us at MAF Pump you get:

- ✓ High-quality pumps, cutting pumps, sludge dewaterers or other products for handling sludge and viscous media. We also offer spare parts for all major brands - always with fast deliveries!
- ✓ Our proprietary AHLEX pump - an acid-proof progressive cavity pump with short installation dimensions to maximise ease of use. This pump is ideal for extra demanding applications!
- ✓ Service in the form of both prevention and repair, or remodelling of pumps and pump houses to suit customer-specific needs.

We have parts to suit all major manufacturers of progressive cavity pumps

We are a complete supplier of spare parts for progressive cavity pumps and can therefore supply parts for several different pump brands. Our range includes components suitable for most major manufacturers, including **AHLEX** (formerly the SE or MAF pump), **Allweiler**, **Bellin**, **Bornemann**, **Kiesel**, **Mono**, **Netzsch/Nemo**, **Nova Rotors**, **PCM**, **Resch**, **Seepex**, **Sydex** and **Cheeks**.



In addition to stators and rotors, we offer a wide range of spare parts for progressive cavity pumps, such as connecting rods, bushings and clamps. In our own workshop, we can also perform various types of special customisation.

Thanks to an extensive stock of stators, rotors and coupling components, we can deliver more than 80% of all orders the same day – quickly, cost-effectively and with reliable uptime.



Suitable spare parts Netzsch

Connecting rod with splines connection, MAF ball coupling (replaces Netzsch arc tooth coupling), link sleeve, clamping ring, castellated nut and sealingcuff, fitting a NEMO pump.



Various drive shafts with removable drive hoodsit, connecting rod, link sleeve, locking pin, coupling bolt, O-rings, lock rings and sealedcuff with clamping ring fitting a NM or NE pump from Nemo/Netzsch.



Suitable spare parts Mono

Connecting rod with bushings, couplingbolt, bolt heads, lock washers and bolts notsande an older Mono pump.



Flexi-shaft fitting a Mono pump type E.



Model B

Mechanical seals

Different types of mechanical seals such as fits most brands on the market.

We offer high quality seals that are adapted for many different models of progressive cavity pumps.



Spare parts suitable for Seepex

Shaft, coupling rod, coupling bolt, connecting rod bushing, guide bushing, jointsleeve, cuff and lashing strap, matching a Seepex pump.

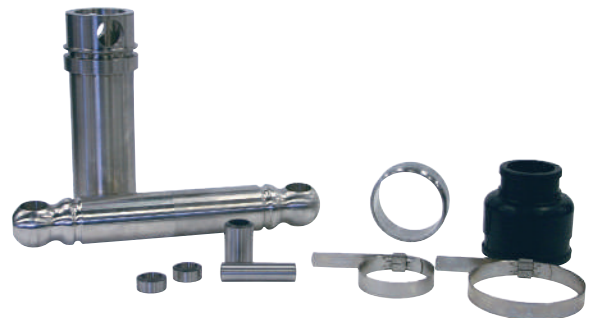

Spare parts suitable for Allweiler

Coupling rod, joint sleeve, joint bushing, guide sleevebolt, coupling bolt and protective collar with clamping strap, fitting an Allweiler pump



Feeding screw

Feeding screw in acid-proof steel, incl. couplingheads and locking pins, for an Allweiler pump type SEZP.



Stators

Manufacturing stators is a highly qualified and demanding process. The tight tolerances required by today's market place high demands on the finished product and require advanced machinery, experienced personnel, extensive material expertise and strong production resources.

Most of our stators are manufactured by Artemis GmbH in Hannover, part of the Jaeger Group and ISO 9001 certified. Since MAF Pump AB was founded in 1991, Artemis has been our main supplier. The steady increase in our market share clearly shows that quality pays off.

Today, our range includes approximately 250 different stator sizes, adapted for pumps from 15 different manufacturers.



Rotors

The fit between rotor and stator is crucial for the pump's performance and service life. At MAF Pump AB, most rotors and stator cores are now manufactured in the same CAD-controlled machine at Artemis GmbH in Hannover, using the same software. This ensures highly precise curves and an optimal fit. The result is correct pump performance, lower energy consumption, longer service life for both stator and rotor, and a reduced risk of start-up problems.



Service close to you

Are you looking for the best possible service for progressive cavity pumps?

We service AHLEX pumps and other progressive cavity pumps, and as the only Swedish distributor of Vaughan chopper pumps and Volute sludge dewatering equipment, we also provide service for these products.

At MAF Pump, we handle everything from preventive maintenance to complete pump rebuilds, such as converting from packed gland seals to mechanical shaft seals. We also offer customer-specific solutions and can, for example, adapt pump housings and feed screws to match your specific operational requirements.

Our service technicians have extensive experience with both chopper pumps and progressive cavity pumps. We can support your maintenance work through service agreements, with service intervals tailored to your needs. Service can be carried out either in our workshop or at your facility.

Contact one of our sales representatives today to develop a service plan tailored to your operation.

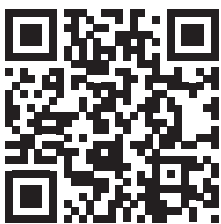

Scan me



CONTACT US FOR MORE INFORMATION



Patrick Nero
Tech salesman, West Sweden
+46 72 – 555 15 73
patrick@mafump.se



Per Karlsson
Tech salesman, South Sweden
+46 70 – 283 84 73
per@mafump.se



Anders Nyström
Tech salesman, East Sweden
+46 70 - 666 56 57
anders.nystrom@mafump.se



Alexander Kindbom
Inside sales
+46 72 – 555 15 93
alexander@mafump.se



Peter Cargerman
Tech salesman, Central Sweden
+46 72 – 580 82 81
peterc@mafump.se

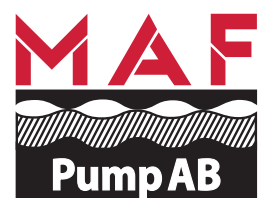

www.mafump.se